

# ASSEMBLY INSTRUCTIONS

## Poly Electric and Non-Electric Drinkers (Models PCPE, PCSE, PHPF, PFL-C, PFL-H, PCHI, PCHE)

### THANK YOU FOR PURCHASING THIS PRODUCT

For questions about this product, or for parts inquiries, please contact our Customer Service Center listed below.

Before beginning, read instructions thoroughly and inspect parts listing to insure that all parts have been included.

#### **Preparation of Location:**

Install drinker on a 4" (minimum) thick concrete base, slightly raised for better drainage. Before pouring concrete, have the water and electricity connected up through a 4" or larger tile for final connections to the drinker. Be sure the edge of the tile is slightly raised above the concrete (approx. 1-1/2") so that water drainage does not go into the open tile. The tile must be left open to give access to warmer air below the frost line, thus preventing the riser from freezing. Be sure the riser pipe does not touch the sides of the tile. **Note:** The concrete pad should be at least 4" larger than the poly CPE drinkers on all sides.

<b>Model</b>	<b>Min. Pad Size</b>	<b>A</b>	<b>B</b>
PCPE	25" x 36"	27.5"	16.5"
PCPI	25" x 36"	27.5"	16.5"
PCSE	25" x 36"	27.5"	16.5"
PCSI	25" x 36"	27.5"	16.5"
PHPF	24" x 44"	35.5"	15.5"
PFL-C	28" x 92"	-	-
PFL-H	28" x 92"	-	-
PCHE	30" x 30"	-	-
PCHI	30" x 30"	-	-
XCPE	40" x 36"	33.0"	28.0"

Place the drinker in the desired position and drill 3/8" dia. x 1-1/2" (min.) deep holes, in the concrete using the molded-in hold down tabs at the base of the drinker as a guide. Cut the proper size hole in the 1" insulation board to fit over the riser tile. It is important to use this insulation board to help insulate and seal the bottom of the drinker. Enough 1" x 3/8" weather strip is included with your drinker to seal the bottom of the drinker to

the concrete base and also to seal the float cover to the drinker. Put weatherstrip on the bottom of the drinker where it contacts with the concrete base. If there are any gaps bigger than 3/8", two layers of weatherstrip can be put together to fill the gap. Please refer to the sketch in these sheets for proper placement of weatherstrip on the float cover. Secure the drinker using 3/8" x 1-7/8" expandable anchor bolts (purchased locally).

#### **Water Line:**

For connection of the drinker to the riser pipe, a high pressure 3/4" I.D. hose is supplied with the drinker. A shut off valve which is easily accessible should be used at each drinker. If the drinker is to be shut down for the winter, a Shut-off Kit (Item No. 54130168) that drains the riser pipe to prevent freezing is available. The supply line should be flushed before drinker is connected. **NOTE:** Your drinker is equipped with a BL valve that is easy to clean and adjust. If low water pressure conditions exist and a higher flow rate is desired, a larger inlet is available (54300968) to increase the flow.

#### **Electrical Connections**

**(for PCPE, PCSE, PHPF, PFL-H & PCHE models only):**

NOTE: Electrical connections should be made by a qualified electrician. The black wire from the power supply must be connected to the thermostat and the white wire from the supply connected to the white wire on the heating pad. The grounding wire from the supply must be connected to the terminal in the electrical box of the drinker.

The unit must be properly grounded to the supply box and fused properly. The fuse size is indicated on the red ground instruction tag.



### CUSTOMER SERVICE CENTER

PO Box 569  
Columbus, NE  
68602-0569

Ph: 1-800-447-2751  
Fax: (402) 563-7447  
www.behlencountry.com

# ASSEMBLY INSTRUCTIONS

Units should be wired according to the ASAE farm wiring recommendations except where different from local regulations.

**NOTE:** The use of the riser pipe as the grounding rod is not recommended. This is due to the extensive use of plastic pipe on the farmsteads and the unknown grounding properties of existing pipe on the site.

**WARNING:** Compliance with the national electric code (CSA in Canada) and local electrical codes must be made and maintained when installing the drinker.

Failure to comply and maintain the drinker to code could result in loss of livestock, severe personal injury, or even death.

### **Adjustment:**

Adjust the float to maintain a water level in the trough of 1" to 1½" below the top of the trough.

### **Warranties:**

All Behlen Country Electric Drinkers carry a 5 year limited warranty on the body and a 1 year limited warranty on valves and controls.

DRINKER MOUNTING LOCATION FOR PFL-H

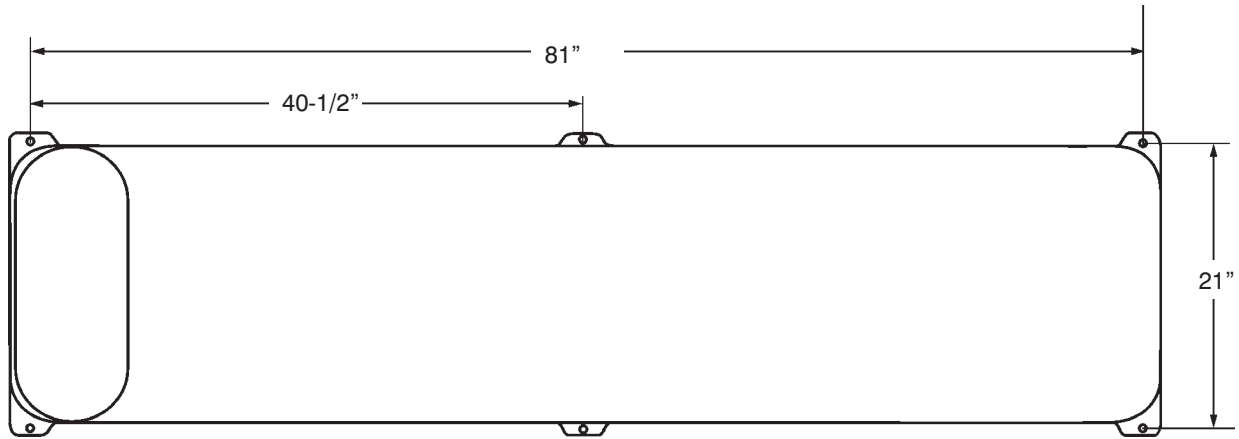

DRINKER MOUNTING LOCATION FOR PCHE AND PCHI

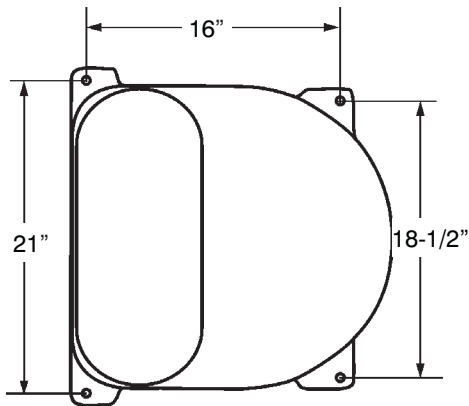

DRINKER MOUNTING LOCATION FOR PCPE, PCPI, PCSE, PCSI, PHPF and XCPE

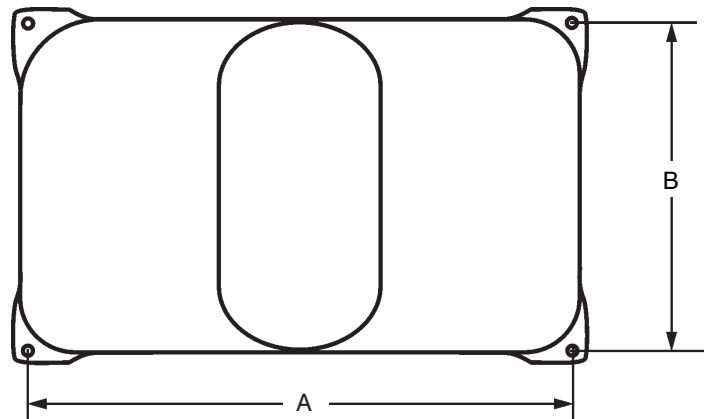

**ASSEMBLY INSTRUCTIONS**

**Applying Weatherstrip to the Float Cover**

2.5 ft. Of Weatherstrip #2048041  
Cut into (4) 3" strips and (2) 8" strips

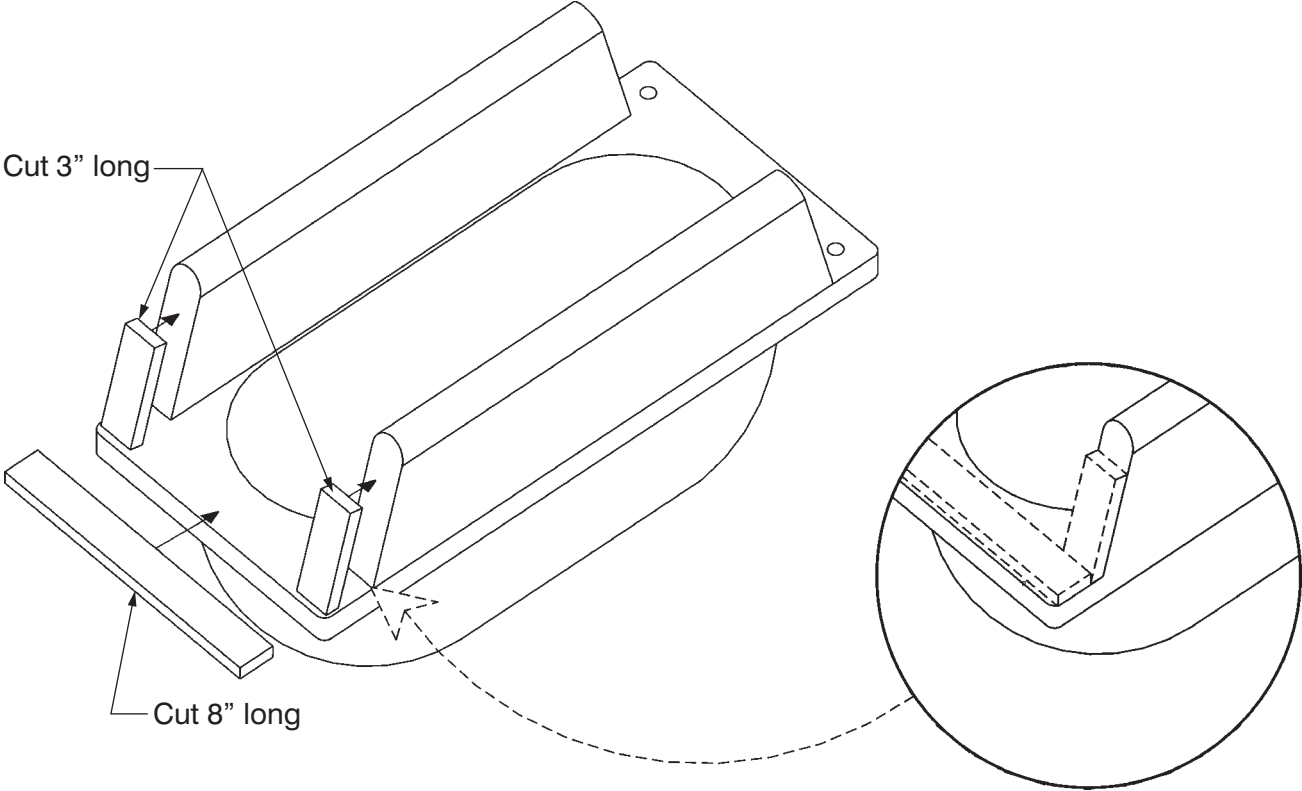

Peel off backing of self-adhering weatherstrips and apply to both sides of Inspection Cover.

Install weatherstrip seal to corners of Inspection Cover as shown.

# ASSEMBLY INSTRUCTIONS

## VIEW INSIDE CAVITY OF DRINKER

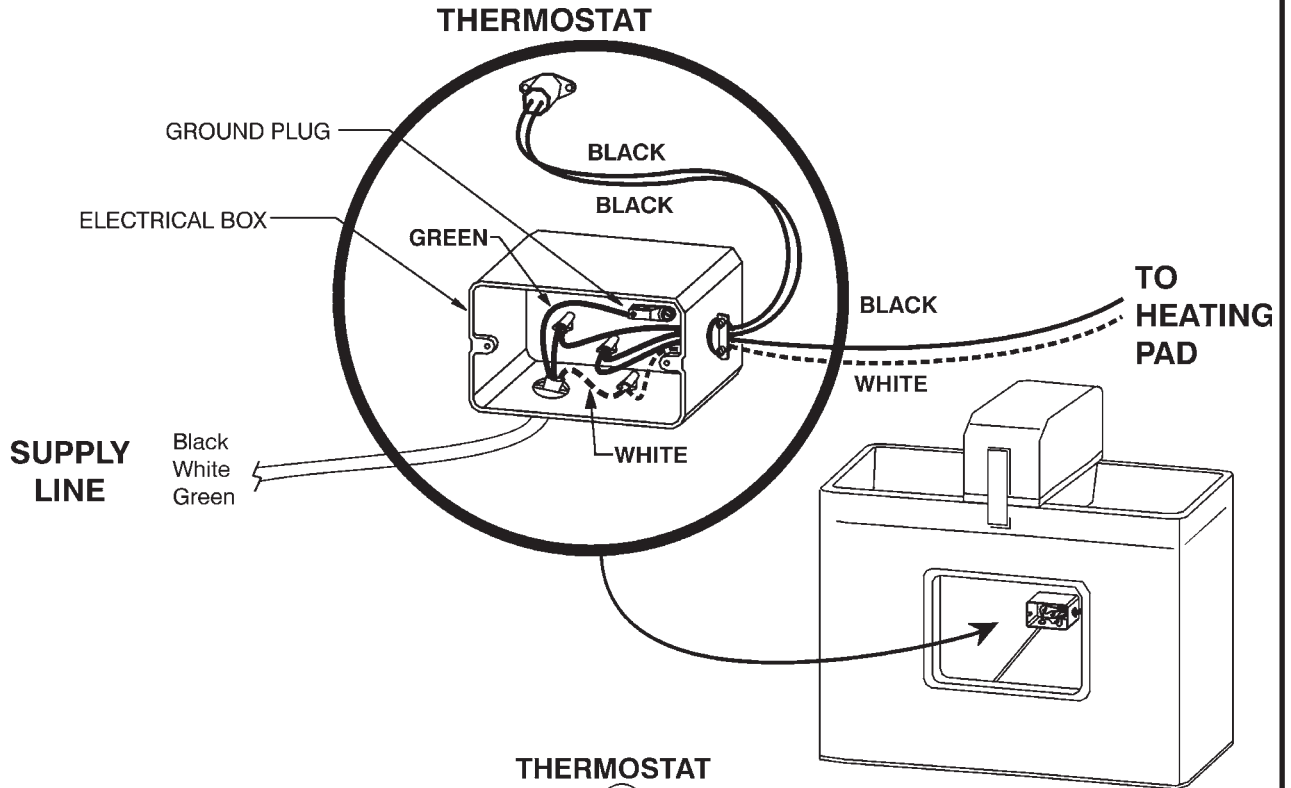

## WIRING SCHEMATIC

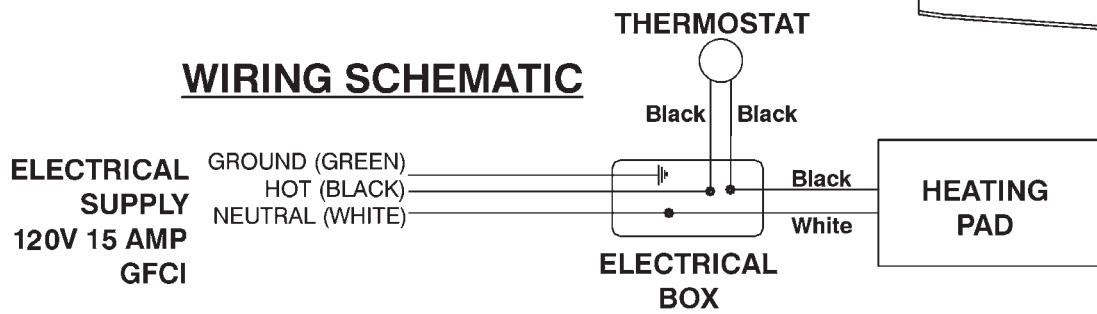

**IMPORTANT NOTE:** Voltage must be grounded and contain Ground Fault Circuit Interruption (GFCI). Contains live electrical components, disconnect power before servicing.

# TROUBLE SHOOTING CHART

## For Behlen Country Electric Drinkers

Ice in Trough	<ul style="list-style-type: none"> <li>• Check fuses or circuit breakers.</li> <li>• Check to see if there are any gaps that allow cold air to enter the base of the drinker.</li> <li>- Make sure the fountain is sealed from wind between the concrete platform and bottom of the drinker.</li> <li>- Make sure there are no air leaks around the access door.</li> <li>• Check to make sure that you have a full 120 volts at the drinker and that the 120 volts are maintained when the heater is on.</li> <li>• Check the heating element to make sure it is working and hot.</li> <li>• Check that heater is wired properly.</li> <li>• Check voltage after thermostat to fountain with and without electrical load (Note: to close the thermostat to complete the circuit, hold a piece of ice in a plastic bag next to sensing surface).</li> <li>• Adjust thermostat to higher temperature by moving it further away from the heat pad (make moves in 2" steps).</li> </ul>
Water Freezing in the Valve or Supply Line	<ul style="list-style-type: none"> <li>• Make sure supply line is properly installed.</li> <li>- Riser tube with supply line centered, and there is an air space between riser tube and supply line.</li> <li>- Horizontal supply line is at least 1' below frost line.</li> <li>• Check for missing or damaged insulation.</li> <li>• Check for air gaps against wind penetrations.</li> <li>- Make sure the fountain is sealed from wind between the concrete platform and bottom of the drinker.</li> <li>- Make sure there are no leaks around the access door.</li> <li>- Make sure that the latches are holding the float cover securely to drinker. If the latches are loose, adjust spring tension on the latch and, if necessary, bend the latch ends in vise thus enabling the latches to hold the cover tighter.</li> </ul>
Valve Won't Stop Dripping or Shut Off	<ul style="list-style-type: none"> <li>• Check the float adjustment. Check for waterlogged float, or float rubbing on side of the valve compartment. Ensure that the float moves freely.</li> <li>• Disassemble valve and check for sand or scale in valve rubber. Also check valve orifice outlet for wear and damage. A screen or filter may be required with sandy or scaly water. Please refer to the valve cleaning instructions supplied with your drinker.</li> <li>• Turn valve rubber over and re-assemble.</li> <li>• Check for excessive water system pressure (greater than 55 psi). If needed, install a pressure regulator, available at most plumbing shops.</li> </ul>
Low Water Flow	<ul style="list-style-type: none"> <li>• Check that the valve inlet is not plugged or supply hose is not kinked.</li> <li>• Check system pressure from supply hose by installing a tee and a pressure gauge directly in front of the valve and then check pressure drop when valve is open. A severe pressure drop indicates a restriction or undersized supply system.</li> <li>• Check that shut off valves are fully open.</li> </ul>

# ASSEMBLY INSTRUCTIONS

## Instructions for Cleaning the Franklin Valve and Replacing the Plunger & Seal

### **STEP 1:**

Remove the packaging tape from around the top of the valve.

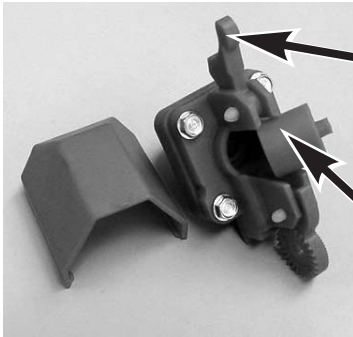
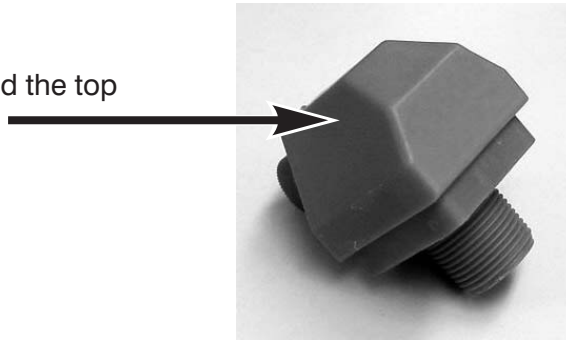

Lever

Plunger

### **STEP 2:**

Slip off the cover and lift the lever to remove the plunger.

### **STEP 3:**

Clean the rubber part of the plunger and opening to the valve of any calcium or dirt buildup that may be obstructing the normal operation of the valve.

Rubber

Valve Opening

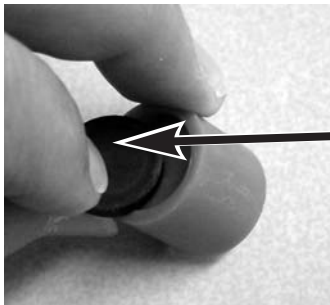
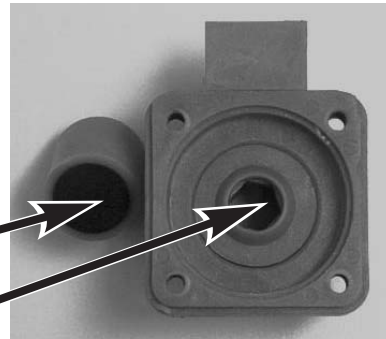

### **STEP 4:**

If the rubber seal is grooved but still pliable (not hard and brittle) you may flip it over and use the backside of the seal.

### **STEP 5:**

Replace the plunger with the nipple facing you, and the rubber facing the valve.

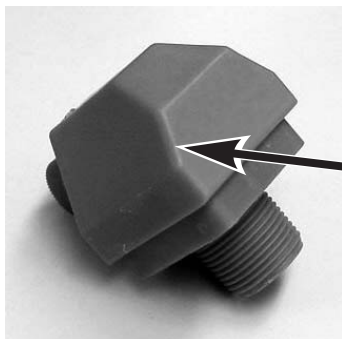
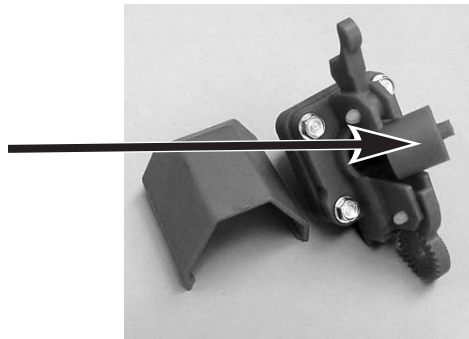

### **STEP 6:**

Replace the cover to complete the cleaning of the valve.

# Franklin BL Valve

